



## **Proactive detection of sag or snapping of conductors in transmission lines**

**Sudha Balagopalan\*, Nikhil S., Gokul Govind**

Department of Electrical & Electronics Engineering  
Vidya Academy of Science & Technology, Thrissur, India  
\*Corresponding author: email: sudha@vidyaacademy.ac.in

**Abstract:** This paper proposes a simple device for proactive detection of excessive sag or snapping of conductor. It is designed and located such that it is affected by the electro-mechanical, operating and environmental conditions that deform and eventually break the conductor. An identical device, impervious to metamorphosis of the conductor, is used for comparison. The concept plan has comparison, processing and transmission of signals regarding imminent failure. Communication is to a central station or to several critically located terminal units for designing the hierarchical level of mitigation. An optimal number of these devices are to be located at vulnerable points on the conductor spans, for each conductor. It is to be clasped on to the conductor and hence is easy to install when the conductor is being laid and when re-conductoring. The simplicity of the device raises expectation of a lower cost at low levels of technology needs, to be suitably scaled up.

*Keywords:* ACSR conductor, proactive detection, sag, sensor

### **1 Introduction**

In a state such as Kerala, with her power portfolio more or less fulfilled by hydro generation it is inevitable that these electric projects have special ecosystems and are located in remote areas. Accordingly the transmission lines cover very long distances and the terrain is generally inhospitable. In such a terrain, any incident of sagging of conductors and its eventual snapping has dire consequences. In addition to electro-mechanical and environmental reasons, in Kerala jungles, elephants and other wild animals have been reported to be the culprits as also victims of such unfortunate occurrences. Such a situation is assuming more and more prominence as Kerala is on a strengthening trend with regard to its power corridors.

When the power corridors are lost or disturbed, evacuation is impossible in areas such as Chalakkudy, Sholayar, etc. as reported recently, virtually islanding the remote generating stations. The economic impact is reportedly huge and the power outage and its outcome are unacceptable in a power deficit state like Kerala. This is because detection of affected locale and subsequent corrective action takes time. In such a terrain, all along, the danger to wild life cannot be ruled out. Moreover, when the conductor is downed, all concerns that high impedance faults raise, are relevant. If not detected and isolated immediately, live downed conductors can be fatal to public and line crewmen. Such faults often lead to arcs and can be a significant fire hazard. It is important to detect a failing conductor before complete failure to avoid power outages and loss of production. Inability to detect Hi-Z faults can cost utilities liabilities and customer service issues. Our proposal is to have a proactive sensing scheme and a modern communication paradigm such that preventive, rather than breakdown maintenance is practiced.

The sensor is of prime importance in proactive detection. It must be borne in mind that, the snapping of conductor is generally the consequence of a prolonged deterioration in the physical structure of the conductor, usually ACSR in Kerala. The first step hence is to collate all causative factors such that the sensor is a part of the continuous monitoring process [1, 2]. And can be a part of the transformation of the conductor over the years. Next step is to have a scheme for comparison such that the electro-dynamism of the power system does not result in unnecessary alarms, especially in the context of remote and stark terrains. Hence, computational designs and experimental validation of thresholds are necessary along with a reference sensor for discrimination purposes. Finally locating the sensors and their paraphernalia, including communication systems are required. Thus the design takes care of the following phases:

1. Design of the mechanical components suitable to the electrical characteristics that enable detection.
2. Setting and justifying the thresholds for discriminating between urgent attention and supervision/comparison.
3. Locating the sensors and communication circuits.

This method cannot be compared with any High Impedance Fault detection methods or a fault locator. Hence all ideas are drawn from theses and text book chapters [3-5] and more or less from Standards and Specifications on ACSR [2,6] and other commonly used conductors. However experimental validation is being done in the authors laboratories now and so is not covered in this paper. The paper is organized to include the other above aspects in subsequent sections.

## **2 Design considerations**

Before detailing the hardware, the ideas that went into the design of the device are examined. The idea is to include the physical excesses that lead to excessive sag in the construct

of the sensor.

## 2.1 Causative factors leading to sag

The study focuses on electro-mechanical flaws, environmental and operating conditions that cause sag and conductor breakage:

1. The main causative factor is creep. Creep in a conductor is attributed partly due to non-elastic, permanent elongation of metal when subjected to load and partly due to settlement of strands. Typically, for a constant stress and temperature level, conductors experience only primary creep and thus obey the power law as given below where  $C$ ,  $m$  are creep coefficients,

$$\text{strain} = Ct^m \quad (1)$$

In general,  $C$  depends on both temperature and the stress level with a similar equation, where  $K$ ,  $n$ ,  $k$  are also coefficients,  $T$  is the temperature in absolute degrees, and "uts" is the ultimate tensile strength of the cable.

$$C = Kt^n(\text{stress}/\text{uts})^k \quad (2)$$

Typically  $m = 0.16$ , varying between 0.13 and 0.19. In real life the tension and temperature changes throughout time. Typically creep is considered at the everyday temperature but with steps of stress levels. In addition, there might be Elevated Temperature Creep, where the cable is operated for a few hours at high temperatures for additional creep but this only applies to cables with a high content of aluminum where the stretched aluminum may reach a compressive state. The amount of creep that can take place in 10, 20, 30, 40 and 50 years has to be studied further. It needs supporting calculations based on everyday tension of 25% of UTS of conductor and temperature of 32°C.

2. The circumference of the conductor is seen to get distorted due to relative movement of the strands, when subjected to tensile forces. The consequent change in cross-sectional area is an interesting feature that can be monitored and used in or as a sensor.
3. Torsion is a common occurrence in a windy location. Specifications of ACSR demand that the conductor withstand a number of twists equivalent to not less than 18 on length equal to 100 times the diameter before fracture occurs. Hence the sensor must record the instances and be indicative and predictive of any such imminent snapping. The device thus has to be location-specific and include such a happenstance.
4. Basically there are three sources of strain- thermal, elastic and plastic (metallurgical creep and strand settling). It is a common practice to convert long term creep into an equivalent value of thermal strain (called the creep compensation temperature). The

creep compensation temperature is subtracted from the actual conductor temperature and the sag is read from the final sag table. Conductors which are not stranded, may undergo an elongation under tensile forces, of not less than 4 percent where as stranded conductors show lesser elasticity, the elongation being about 3.5 percent or a little more. The device must be sensitive to different elasticity requirements. The formula is

$$T_c = \frac{E_f - E_i}{a} \quad (3)$$

where  $T_c$  is temperature compensation ( $^{\circ}\text{C}$ ),  $E_f$  is final creep strain at say 10 years,  $E_i$  is initial creep strain at time of sag, and  $a$  is coefficient of thermal expansion ( $/^{\circ}\text{C}$ ). Equivalence conditions for projections for 5 decades, decade by decade are to be established and included in the experiments. Creep strain is a function of conductor stress (tension), temperature and duration. Coefficients for any creep prediction equation can be collected from the conductor manufacturers. Since the conductor tension reduces as the conductor ages, calculating the creep with a time step of 10 years will result in a larger value of creep than say ten 1 year time steps. Allowances should be made for additional strand settling that occurs if the conductor experiences a heavy load during its lifetime.

5. Both aluminum and galvanized steel components of the conductor are susceptible to breakage or cracks due to jointing by wrapping one over the other.
6. With compression type dead end clamps on both ends, in such manner as to permit the conductor to take its normal straight line shape, when subjected to a tension of say 50 percent of the UTS of the conductor, the result is that the surface departs from its cylindrical shape or the strands move relative to each other so as to get out of place or disturb the longitudinal smoothness of conductor. Conductor specifications do not accept that the diameter at any place is less than the sum of the minimum specified diameters of the individual aluminum and steel strands.
7. Both aluminum and galvanized steel components of the conductor are susceptible to breakage or cracks due to jointing by wrapping one over the other.
8. With compression type dead end clamps on both ends, in such manner as to permit the conductor to take its normal straight line shape, when subjected to a tension of say 50 percent of the UTS of the conductor, the result is that the surface departs from its cylindrical shape or the strands move relative to each other so as to get out of place or disturb the longitudinal smoothness of conductor. Conductor specifications do not accept that the diameter at any place is less than the sum of the minimum specified diameters of the individual aluminum and steel strands.
9. Due to wind and ice, the transmission lines swing under different modes. The transmission lines may vibrate in three major ways as detailed below.

- (a) **Galloping:** Due to the deposit of ice above conductor surface, the conductor cross section resembles an aerofoil. The wind flowing across the conductor (aerofoil) results in Galloping of conductor. Galloping is the oscillation of the conductor at high amplitude and low frequency. The conductor may oscillate in vertical or horizontal plane, generally in a vertical plane. The amplitude of oscillation may be more than a meter, with frequency up to 3 Hz. Due to galloping the clearance between the conductors may reduce very much to initiate flashover. Structural damage may also happen due to conductor galloping.
- (b) **Aeolian vibration:** When wind flows across the line steadily then vortices are formed in the back side of conductor which causes Aeolian vibration. Here the amplitude is in millimeter or centimeter and frequency may be up-to 150 Hz. Over a long time the Aeolian vibration may cause damage to the strands of wire.
- (c) **Wake induced vibration:** Wake induced vibration takes place in bundled conductors. The aerodynamic forces in the downstream of conductor, cause such oscillations. They have amplitude in centimeters. The above aspects suggest that scope exists for inducing both static and dynamic voltages in a coil with common flux linkages with the ACSR conductor. Moreover it varies, depending on the rate of change of this flux linkage. Hence dimensional changes wrought on any iron material or clasp and an air gap can be used to advantage as sensors, in tandem with the ACSR conductor, used as a transmission line, and which is analyzed below.

## 2.2 Analysis of ACSR for design of sensors

The computations for the sensor design, uses formulae for sag, conductor slack and linear expansion (of both iron and Al) and are given in Appendix and [1]. The case study is based on the Drake ACSR conductor and in [1,2] considers a span of 600ft with specifications given in Table I to derive information. The computations show that sag alone accounts for a slack of 0.0826m, and it is independent of weight, tension or temperature. Thermal expansion accounts for 0.21m for a temperature rise of 60°C from 15°C. Then there is a release in tension but since neither wind nor ice loading is considered, it is reasonable to expect a total elongation of 0.3 m in every span of 180m. If this reduces the diameter of the cable by 0.03mm as assumed here, an air gap of 1mm can be used in the clasp designed and shown in Fig. 2. Some of the inferences are the following.

1. With a steel core, and Aluminum strands surrounding it, the ferromagnetic property of the core can be used to induce emfs in external coils. The inductance of this external coil will depend both on the length of the core it encompasses as also the cross-sectional area of the core, providing the flux linkage.
2. If an external ferromagnetic clasp is used which has circumferential elasticity, elongation and thinning of the conductor results in tightening of the clasp around it. This

<b>Data sheets of 2 types of ACSR</b>		
<b>Properties</b>	<b>DRAKE</b>	<b>ZEBRA</b>
Al. used	26/4.442 mm	54/3.18 mm
Steel used	7/3.454 mm	7/3.18 mm
Overall diameter	28.133 mm	28.62 mm
Sectional area of Al.	402.9 mm <sup>2</sup>	428.9 mm <sup>2</sup>
Overall cross sectional area	468.51 mm <sup>2</sup>	484.5 mm <sup>2</sup>
Approximate weight	1626 kg./km	1621 kg./km
Ultimate tensile strength	14288 kg	13284 kg
Final modulus of elasticity	6894.8 kg./mm <sup>2</sup>	7034 kg./mm <sup>2</sup>
Coefficient of linear expansion	18.90×10-6/°C	19.30×10-6/°C
Circumference	90mm	90 mm

Table 1: Specifications for ACSR conductors for a span of 60m (180ft)

reduces a designed air gap length and hence the reluctance of the iron path, entailing an increase in flux flow and hence induced emf.

Both methods require choice of materials and their dimensional design and computation, which we specify in the next section.

### 2.3 Computational design of sensors

Two designs are proposed and corresponding computations given here.

#### 1. With an internal iron core (a part of ACSR)

The stress-strain relationship of the Drake conductor indicates that there is an elongation of about 0.55 m when the stress is half its breaking strength, in a span of 180m. Otherwise also, a 3.5% elongation is expected, under tensile forces and hence this figure is a safe assumption. So a coil of original length, 30 cms, gains about 1 mm on either sides, that is, an increase of 0.7%. Simultaneously The cross sectional area decreases by about 0.6625%. The overall decrease of inductance is thus 98.65%, which is perceptible and with good magnetic materials and larger number of turns can be converted to measurable values of induced emf.

#### 2. With an external iron clasp

In this model, an iron clasp with a cross sectional area of 6 mm<sup>2</sup>, with a designed circumferential length of 100 mm, and air-gap of 2 mm, when  $\mu_r = 800$ , there is a total peak voltage difference of about 3 to 4 volts for every 10A flow through the conductor, when 100 turns are used in the inductive device.

The above computations add significance to the design of the electro-magnetic-mechanical sensor.

### **3 Design of the electro-mechanical devices**

#### **3.1 Proposed methodology**

The first step is to identify all the distinguishable factors that cause sag and investigate whether there are perceptible mechanical changes in the conductor. Hence a sample, the 26/7 Drake ACSR conductor, was chosen, which has been well analyzed in [1] and the ideas are compared to ACSR Zebra, which has been specified comprehensively in [2,6].

The study of the causative factors and specifications of the commonly used conductors suggested a simple electro-mechanical device. Its magnetic properties continue to alter and reaches an identifiable threshold as snapping becomes imminent. This meant that another identical device which is not subjected to sag or wind or other mechanical assaults is required for comparison. Thus the scheme requires two coils, one of which is affected by the temperaments and clasped onto the ACSR conductor. The other coil has to be mounted on a safe location such as the tower top, with the jumper carrying the same line current passing through it, a comparator and the communication circuit, the schematic of which is given below in a simple flow chart (Fig. 1). If assault by environment affects the conductor, a similar effect must impact the device also, is the conceptual idea. Both inordinate sag and structural deformation lead to impending conductor snapping and is put to use for detection, via any effect produced. One effect of dimension change of iron, like elongation and area reduction, is on magnetism. Hence the first model for the device as given in Fig. 2 uses the elongation of the ferromagnetic core and its simultaneous reduction in area to reduce the inductance of a coil wound on the conductor. Its twin, when not subjected to a similar mechanical deformation, carries the same current through the conductor, but its magnetic path is not affected and hence, helps to discriminate between the 2 situations. A play or gap for oscillations, given to the former or bobbin, with respect to the conductor results also in dynamically induced emfs in the sensor when subject to Galloping, Aeolian or wake induced vibrations, consequent to winds. The specifications are as follows:

- i. 1000 turns on a non-magnetic former
- ii. Length of the solenoid: 30 cm.
- iii. Iron core data: depends on the ACSR core
- iv. Play for the conductor and bobbin: 1-2 mm

In the second model, a clasp like ferromagnetic material is planned with a designed air gap, such that the reluctance of the iron circuit is a critical and decisive entity. Hence, the induced emf in the coil placed on the clasp, has an increased level compared to an identical sensor, not subjected to the climes, but flux being set up by the same current flowing through the ACSR conductor.

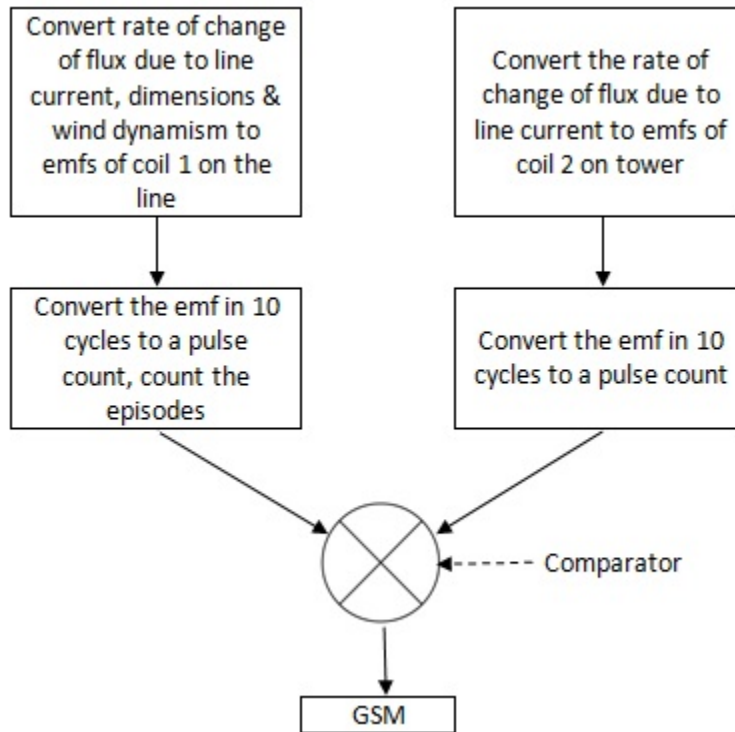

Figure 1: Flow Chart recounting the scheme or the model

- i. 100 turns of fine copper wire wound on the clasp
- ii. Air gap length-1mm (depends on the ACSR core)
- iii. Ferromagnetic clasp of iron, nickel, cobalt or permalloy exhibiting magneto-elasticity.

Attempt will next be made to incorporate in the sensors, the potential or capability of Matteucci effect. It is manifested as a change of magnetization of materials like iron, nickel, cobalt or permalloy on torsional stress. The sensitivity of magnetic induction, with respect to stress, depends on saturation magnetization, relative permeability, saturation magnetostriction coefficient and domain configuration [1,2].

With these sensors, theoretically, thresholds are set for detection and validated experimentally. The location of the sensors is also important for comparison and discrimination. This is dealt with next.

### 3.2 Detection, location and thresholds

The nodal points must differentiate between the different situations for detection as given below.



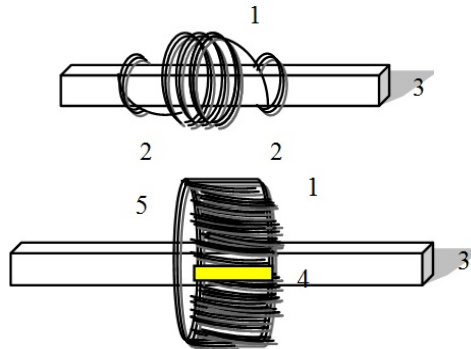

1. Inductive sensor
2. Binding wire
3. ACSR conductor
4. Air Gap
5. Ferromagnetic clasp

Figure 2: Basic constructional details of the sensor device

1. Before snapping, due to elongation of the conductor strands beyond set values, the sensor coil too gets stretched, being held by the binding wire. Thus the related change in the flux linked, results in a voltage difference between the two nodes. This voltage difference is used as the source for detection. (This applies to salt deposits as well.)
2. Another situation is when the area of the ACSR conductor gets distorted or reduced due to elongation or non-uniform stretching of conductors. Due to tightening of the iron core clasp onto the conductor, there is reduction of air gap, which also gives rise to a voltage differential, to be suitably amplified and conveyed.
3. The physical oscillations described above, also result in dynamically induced emfs to be again processed and modified to detection levels and transmitted. In addition, embedded systems along with LVDT transducers on towers and posts can be used to identify continuous physical deformation and transmitted.

Though the workings of the sensors are anti-thesis to each other, the manner in which the signals are generated and used for detection and subsequent communication are similar. The ends of either inductive coils are brought out and the induced emf converted to pulses, and counted in a predetermined duration. Thereafter the numbers of pulses that indicate approaching snapping are analyzed and the thresholds set, depending upon the sensor type used. This is how most of the above mentioned causative factors, creep, circumferential aberrations, torsion, strain, climate and construction or erection based deterioration and vibrations etc. are integrated into the electro-mechanical device for proactive detection. In our approach, we use the same features to generate signals for identifying sag reaching predetermined thresholds at the identified locations in the conductor.

The location of sensors is crucial. The most vulnerable points, with reference to the terrain and accessibility must be identified to locate the sensors that are to detect savagery

on the ACSR. An optimal number of these devices are located at vulnerable points on the conductor spans, between posts or towers, one for each conductor. The other sensor must be such that it is not afflicted by the climes. The conceptual plan includes means of transmitting these signals to a central station or to several critically located terminal units for processing the signals, for designing the hierarchical level of mitigation. A protocol for execution of proactive measures or to set up a hierarchy for operations needs to be instituted.

#### **4 The communication paradigm**

The communication protocol is briefly explained.

1. Set relay 1, relay 2
2. Setting threshold values for microcontroller
3. Set time
4. Comparing the parameter with the input value at each time interval
5. If no limit violations then go to step 6 else to step 7
6. Go to step 4
7. If values become zero (accidental snap or slip), then go to step 8 else to step 11
8. Tripping (at transformer area) and alarm (at controlling station)
9. Sending message to controlling station from transformer station through GSM network
10. Action
11. Comparing the cross section of lines (in the case of ice deposit)
12. If the value is within the limits go to step 4
13. Communication to the controlling station through GSM network
14. Comparing the clearance between lines (wind oscillations)
15. If the value is within the limits go to step 4
16. Communication to the controlling station through GSM network
17. Checking leakage currents at insulator (due to salt deposit)
18. If leakage currents are present, step 18 else to step 4
19. Communication to the controlling station through GSM network

20. Checking the values of amplitude of vibration
21. If value of amplitude exceeds the pre-set value, go to step 21 else to step
22. Communication to the controlling station through GSM network

## 5 Conclusions

A simple device with elementary details and scheme is given here. As a future work, all benefits that Matteucci effect, ferromagnetism and permeability can bring to it are to be incorporated. The device can be made applicable to any voltage levels through a pre-programmable setting of thresholds and limits. Field programmable gate arrays may also be included for future eventualities. The tower or structures bearing the conductor is also to be provided stress relieving and line tightening gears and paraphernalia commensurate with the requirement. The simplicity of the device raises expectation of a lower cost at low levels of technology needs, to be suitably scaled upwards.

## References

- [1] F. Ridley Thrash, Jr. Transmission Conductors - A Review of the Design and Selection Criteria. <http://www.southwire.com/support/>
- [2] D.A Doiuglass, Ridley Thrash, 2007, "Sag and Tension of Conductor," Ch. 14 in "Electric Power Generation, Transmission and Distribution." Ed. Leonard Grigsby, CRC Press, Taylor & Francis Group USA
- [3] Anouar Behlacen, 2004, "Magnetoelasticity, Magnetic forces and Magnetostriction in Electric Machines", PhD Thesis submitted at Helsinki University of Technology, Finland.
- [4] John Tengdin, Ron Westfall, Kevin Stephan, High Impedance Fault Detection Technology Report of PSRC Working Group D15.
- [5] Solmon Yuping Shen, 2003 Development of high sensitivity materials for applications in magneto-mechanical torque sensor. A masters thesis submitted Iowa State University.
- [6] <http://www.ctw.co.th/Catalog/Aluminium/alu-24-28.pdf> (pp.51 - 72)

## Appendix

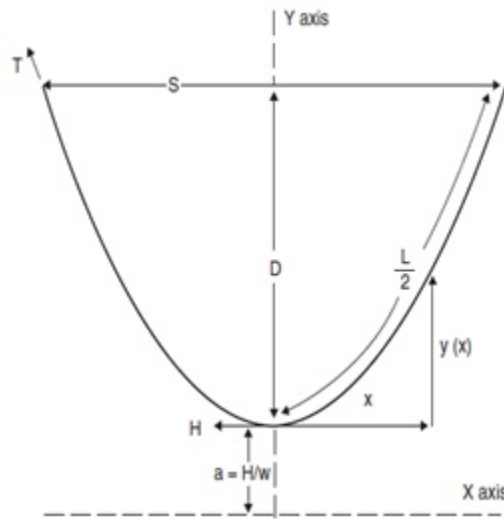

$$\begin{aligned}
 y(x) &= \frac{H}{w} \cosh \left( \left( \frac{w}{H} x \right) - 1 \right) \\
 &= \frac{w}{2H} x^2, \text{ approximately.} \\
 D &= \frac{H}{w} \cosh \left( \left( \frac{ws}{2H} \right) - 1 \right) \\
 &= \frac{w}{8H} s^2, \text{ approximately.} \\
 L &= \left( \frac{2H}{w} \right) \sinh \left( \frac{sw}{2H} \right) \\
 &= s \left( 1 + \frac{s^2 w^2}{24H^2} \right), \text{ approximately.}
 \end{aligned}$$

Modulus of elasticity:

$$\begin{aligned}
 E_{AS} &= E_{AL} \left( \frac{A_{AL}}{A_{Total}} \right) + E_{ST} \left( \frac{A_{ST}}{A_{Total}} \right) \\
 \alpha_{AS} &= \alpha_{AL} \left( \frac{E_{AL}}{E_{AS}} \right) \left( \frac{A_{AL}}{A_{Total}} \right) + \alpha_{ST} \left( \frac{E_{ST}}{E_{AS}} \right) \left( \frac{A_{ST}}{A_{Total}} \right)
 \end{aligned}$$

where we have:

$E_{AL}$  = Elastic modulus of aluminum, psi

$E_{ST}$  = Elastic modulus of steel, psi

$E_{AS}$  = Elastic modulus of aluminum-steel composite, psi

$A_{AL}$  = Area of aluminum strands, square units

$A_{ST}$  = Area of steel strands, square units

$A_{Total}$  = Total cross-sectional area, square units

$\alpha_{AL}$  = Aluminum coefficient of linear thermal expansion, per ° F

$\alpha_{ST}$  = Steel coefficient of thermal elongation, per ° F

$\alpha_{AS}$  = Composite aluminium-steel coefficient of thermal elongation, per ° F